

## CE EMC Test Report (EN 50155 & EN 50121-3-2)

**Report No.:** CE200316D05-1

**Test Model:** PE-5004

**Series Model:** PE-5XXXXXXXXXXXXXXXXX ("X" can be 0-9, A-Z or blank for marketing purpose)

**Received Date:** Mar. 16, 2020

**Test Date:** Mar. 19 to 30, 2020

**Issued Date:** Apr. 6, 2020

**Applicant:** Vecow Co.,Ltd.

**Address:** 3F., No.10, Jiankang Rd., Zhonghe Dist., New Taipei City 23586, Taiwan

**Issued By:** Bureau Veritas Consumer Products Services (H.K.) Ltd., Taoyuan Branch  
Lin Kou Laboratories

**Lab Address:** No. 47-2, 14th Ling, Chia Pau Vil., Lin Kou Dist., New Taipei City, Taiwan



This report is for your exclusive use. Any copying or replication of this report to or for any other person or entity, or use of our name or trademark, is permitted only with our prior written permission. This report sets forth our findings solely with respect to the test samples identified herein. The results set forth in this report are not indicative or representative of the quality or characteristics of the lot from which a test sample was taken or any similar or identical product unless specifically and expressly noted. Our report includes all of the tests requested by you and the results thereof based upon the information that you provided to us. You have 60 days from date of issuance of this report to notify us of any material error or omission caused by our negligence, provided, however, that such notice shall be in writing and shall specifically address the issue you wish to raise. A failure to raise such issue within the prescribed time shall constitute your unqualified acceptance of the completeness of this report, the tests conducted and the correctness of the report contents. Unless specific mention, the uncertainty of measurement has been explicitly taken into account to declare the compliance or non-compliance to the specification. The report must not be used by the client to claim product certification, approval, or endorsement by A2LA, or any agency of the U.S. government. The report must not be used by the client to claim product certification, approval, or endorsement by TAF or any government agencies.

## Table of Contents

<b>Release Control Record</b> .....	<b>4</b>
<b>1 Certificate of Conformity</b> .....	<b>5</b>
<b>2 Summary of Test Results</b> .....	<b>6</b>
2.1 Performance Criteria .....	9
2.2 Measurement Uncertainty .....	9
2.3 Modification Record.....	9
<b>3 General Information</b> .....	<b>10</b>
3.1 Description of EUT .....	10
3.2 Features of EUT .....	10
3.3 Operating Modes of EUT and Determination of Worst Case Operating Mode .....	10
3.4 Test Program Used and Operation Descriptions.....	11
3.5 Primary Clock Frequencies of Internal Source .....	11
<b>4 Configuration and Connections with EUT</b> .....	<b>12</b>
4.1 Connection Diagram of EUT and Peripheral Devices.....	12
4.2 Configuration of Peripheral Devices and Cable Connections.....	15
<b>5 Conducted Disturbance at Auxiliary a.c. or d.c. Power Ports</b> .....	<b>17</b>
5.1 Limits .....	17
5.2 Test Instruments .....	17
5.3 Test Arrangement.....	18
5.4 Test Results.....	19
<b>6 Radiated Disturbance up to 1 GHz</b> .....	<b>21</b>
6.1 Limits .....	21
6.2 Test Instruments .....	21
6.3 Test Arrangement.....	22
6.4 Test Results.....	23
<b>7 Radiated Disturbance above 1 GHz</b> .....	<b>25</b>
7.1 Limits .....	25
7.2 Test Instruments .....	25
7.3 Test Arrangement.....	26
7.4 Test Results.....	27
<b>8 Electrostatic Discharge Immunity Test (ESD)</b> .....	<b>29</b>
8.1 Test Specification.....	29
8.2 Test Instruments .....	29
8.3 Test Arrangement.....	30
8.4 Test Results.....	31
<b>9 Radio-frequency Electromagnetic Field Immunity Test (RS)</b> .....	<b>33</b>
9.1 Test Specification.....	33
9.2 Test Instruments .....	33
9.3 Test Arrangement.....	34
9.4 Test Results.....	35
<b>10 Electrical Fast Transient/Burst Immunity Test (EFT)</b> .....	<b>36</b>
10.1 Test Specification.....	36
10.2 Test Instruments .....	36
10.3 Test Arrangement.....	37
10.4 Test Results.....	37

<b>11</b>	<b>Immunity to Conducted Disturbances Induced by RF Fields (CS)</b> .....	<b>38</b>
11.1	Test Specification.....	38
11.2	Test Instruments .....	38
11.3	Test Arrangement .....	39
11.4	Test Results .....	40
<b>12</b>	<b>Pictures of Test Arrangements</b> .....	<b>41</b>
12.1	Conducted Disturbance at Auxiliary a.c. or d.c. power ports .....	41
12.2	Radiated Disturbance up to 1 GHz .....	42
12.3	Radiated Disturbance above 1 GHz.....	43
12.4	Electrostatic Discharge Immunity Test (ESD) .....	44
12.5	Radio-frequency Electromagnetic Field Immunity Test (RS) .....	45
12.6	Fast Transients (EFT).....	46
12.7	Radio-frequency common mode (CS).....	46
	<b>Appendix – Information of the Testing Laboratories</b> .....	<b>47</b>

### Release Control Record

Issue No.	Description	Date Issued
CE200316D05-1	Original release.	Apr. 6, 2020

## 1 Certificate of Conformity

**Product:** PCI Express 10G PoE+ Expansion Card

**Brand:** Vecow

**Test Model:** PE-5004

**Series Model:** PE-5XXXXXXXXXXXXXXXXX ("X" can be 0-9, A-Z or blank for marketing purpose)

**Sample Status:** Engineering sample

**Applicant:** Vecow Co.,Ltd.

**Test Date:** Mar. 19 to 30, 2020

**Standards:** **EN 50155:2017, Clause 13.4.8**  
**EN 50121-1:2017**  
**EN 50121-3-2:2016**  
EN 61000-4-2:2009  
EN 61000-4-3:2006 +A1:2008 +A2:2010  
EN 61000-4-4:2012  
EN 61000-4-5:2014 +A1:2017 (Not applicable)  
EN 61000-4-6:2014 +AC:2015

The above equipment has been tested by **Bureau Veritas Consumer Products Services (H.K.) Ltd., Taoyuan Branch**, and found compliance with the requirement of the above standards. The test record, data evaluation & Equipment Under Test (EUT) configurations represented herein are true and accurate accounts of the measurements of the sample's EMC characteristics under the conditions specified in this report.

**Prepared by :**  , **Date:** Apr. 6, 2020  
Vivian Chen / Specialist

**Approved by :**  , **Date:** Apr. 6, 2020  
Jim Hsiang / Associate Technical Manager

## 2 Summary of Test Results

EN 50121-3-2:2016, Emission requirements, EN 50155:2017, Clause 13.4.8			
Port	Test Item / specifications	Result/Remarks	Verdict
Auxiliary a.c. or d.c. power ports - Auxiliary supply sinusoidal a.c. or d.c.	Conducted disturbance 150 kHz- 500 kHz: 99 dB $\mu$ V quasi-peak 500 kHz- 30 MHz: 93 dB $\mu$ V quasi-peak	Minimum passing margin is -30.20 dB at 0.25125 MHz	Pass
Auxiliary a.c. or d.c. power ports – AC power outlet port for public use	Conducted disturbance 50 Hz- 2 kHz: THD <8% (THD: total harmonic distortion)	Test not applicable because the port does not exist.	N/A
Battery referenced ports - Battery power supply	Conducted disturbance 150 kHz- 500 kHz: 99 dB $\mu$ V quasi-peak 500 kHz- 30 MHz: 93 dB $\mu$ V quasi-peak	Test not applicable because the port does not exist.	N/A
Enclosure	Radiated disturbance 30 MHz- 230 MHz: 40 dB $\mu$ V/m quasi-peak 230 MHz -1 GHz: 47 dB $\mu$ V/m quasi-peak	Minimum passing margin is -0.73 dB at 151.49 MHz	Pass
Enclosure	Radiated disturbance 1 GHz- 3 GHz: 76 dB $\mu$ V/m peak 56 dB $\mu$ V/m average 3 GHz - 6 GHz: 80 dB $\mu$ V/m peak 60 dB $\mu$ V/m average	Minimum passing margin is -11.68 dB at 1500.20 MHz	Pass

EN 50121-3-2:2016, Immunity requirements,  
 EN 50155:2017, Clause 13.4.8

Table Clause	Basic standard	Port	Test Item / specifications	Result/Remarks	Verdict
3.1	EN 61000-4-6:2014 +AC:2015	Battery referenced ports (except at the output of energy sources), Auxiliary a.c. power input ports (rated voltage $\leq 400$ Vrms)	Radio-frequency common mode (CS) 80% AM (1kHz) 0.15-80 MHz, 10V Performance Criterion A	Test not applicable because the port does not exist.	N/A
3.2	EN 61000-4-4:2012	Battery referenced ports (except at the output of energy sources), Auxiliary a.c. power input ports (rated voltage $\leq 400$ Vrms)	Fast Transients (EFT) 5/50 ( $t_r/t_w$ ) ns, 5kHz $\pm 2$ kV Performance Criterion A	Test not applicable because the port does not exist.	N/A
3.3	EN 61000-4-5:2014 +A1:2017	Battery referenced ports (except at the output of energy sources), Auxiliary a.c. power input ports (rated voltage $\leq 400$ Vrms)	Surges 1.2/50 (8/20) ( $T_f/T_d$ ) $\mu$ s Line to ground: $\pm 2$ kV 42 $\Omega$ , 0.5 $\mu$ F Line to line: $\pm 1$ kV 42 $\Omega$ , 0.5 $\mu$ F Performance Criterion B	Test not applicable because the port does not exist.	N/A
4.1	EN 61000-4-6:2014 +AC:2015	Signal & communication, process measurement & control ports	Radio-frequency common mode (CS) 80% AM (1kHz) 0.15-80 MHz, 10V Performance Criterion A	Performance Criterion A	Pass
4.2	EN 61000-4-4:2012	Signal & communication, process measurement & control ports	Fast Transients (EFT) 5/50 ( $t_r/t_w$ ) ns, 5kHz $\pm 2$ kV, Capacitive clamp Performance Criterion A	Performance Criterion A	Pass
5.1	EN 61000-4-3:2006 +A1:2008 +A2:2010	Enclosure ports	Radio-frequency electromagnetic field amplitude modulated (RS) <sup>1</sup> , 80% AM (1kHz) 80-800 MHz, 20V/m Performance Criterion A	Performance Criterion A	Pass
5.2	EN 61000-4-3:2006 +A1:2008 +A2:2010	Enclosure ports	Radio-frequency electromagnetic field from digital mobile telephones (RS) <sup>2</sup> , 80% AM (1kHz) 800-1000 MHz, 20V/m 1400-2000 MHz, 10V/m 2000-2700 MHz, 5V/m 5100-6000 MHz, 3V/m Performance Criterion A	Performance Criterion A	Pass

EN 50121-3-2:2016, Immunity requirements,  
EN 50155:2017, Clause 13.4.8

Table Clause	Basic standard	Port	Test Item / specifications	Result/Remarks	Verdict
5.3	EN 61000-4-2:2009	Enclosure ports	Electrostatic Discharges (ESD) ±6kV Contact discharge ±8kV Air discharge Performance Criterion B	Performance Criterion B	Pass

Note 1: This limit applies to equipment mounted in the passenger compartments, drivers cab or external to the rolling stock (roof, underframe). For equipment mounted in all other areas a severity level of 10 V/m may be used.

Note 2: For large apparatus (e.g. traction drives, auxiliary converters) it is often not practical to perform the immunity test to radiated electromagnetic fields on the complete unit. In such cases the manufacturer should test susceptible sub-systems (e.g. control electronics). The test report should justify the selection or not of sub-systems and any assumptions made (e.g. reduction of field due to case shielding).

Note:

1. There is no deviation to the applied test methods and requirements covered by the scope of this report.
2. The above EN basic standards are applied with latest version if customer has no special requirement.
3. Determining compliance based on the results of the compliance measurement, not taking into account measurement instrumentation uncertainty.
4. N/A: Not Applicable



## 2.1 Performance Criteria

### General Performance Criteria

The general performance criteria apply for those ports for which no specific performance criteria are defined (e.g. auxiliary ports) in the report.

**Performance criterion A:** The apparatus shall continue to operate as intended during and after the test. No degradation of performance or loss of function is allowed below a performance level specified by the manufacturer, when the apparatus is used as intended. The performance level may be replaced by a permissible loss of performance. If the minimum performance level or the permissible performance loss is not specified by the manufacturer, either of these may be derived from the product description and documentation, and from what the user may reasonably expect from the apparatus if used as intended..

**Performance criterion B:** The apparatus shall continue to operate as intended after the test. No degradation of performance or loss of function is allowed below a performance level specified by the manufacturer, when the apparatus is used as intended. The performance level may be replaced by a permissible loss of performance. During the test, degradation of performance is however allowed. No change of actual operating state or stored data is allowed. If the minimum performance level or the permissible performance loss is not specified by the manufacturer, either of these may be derived from the product description and documentation, and from what the user may reasonably expect from the apparatus if used as intended.

**Performance criterion C:** Temporary loss of function is allowed, provided the function is selfrecoverable or can be restored by the operation of the controls.

## 2.2 Measurement Uncertainty

Where relevant, the following measurement uncertainty levels have been estimated for tests performed on the EUT as specified in CISPR 16-4-2:

Measurement	Expanded Uncertainty (k=2) ( $\pm$ )	Maximum allowable uncertainty ( $\pm$ )
Conducted disturbance at mains port using AMN, 150kHz ~ 30MHz	2.94 dB	3.4 dB ( $U_{\text{CISPR}}$ )
Radiated disturbance, 30MHz ~ 1GHz	4.25 dB	6.3 dB ( $U_{\text{CISPR}}$ )
Radiated disturbance, 1GHz ~ 6GHz	4.61 dB	5.2 dB ( $U_{\text{CISPR}}$ )

The other instruments specified are routine verified to remain within the calibrated levels, no measurement uncertainty is required to be calculated.

## 2.3 Modification Record

There were no modifications required for compliance.

### 3 General Information

#### 3.1 Description of EUT

Product	PCI Express 10G PoE+ Expansion Card
Brand	Vecow
Test Model	PE-5004
Series Model	PE-5XXXXXXXXXXXXXXXXX ("X" can be 0-9, A-Z or blank for marketing purpose)
Model Difference	For marketing purpose
Sample Status	Engineering sample
Operating Software	N/A
Power Supply Rating	DC power from IPC
Accessory Device	N/A
Data Cable Supplied	N/A

Note:

1. The EUT is a PCI Express 10G PoE+ Expansion Card and installed in IPC during the test.
2. The EUT maximum data rate is 10Gbps.

#### 3.2 Features of EUT

The tests reported herein were performed according to the method specified by Vecow Co.,Ltd., for detailed feature description, please refer to the manufacturer's specifications or user's manual.

#### 3.3 Operating Modes of EUT and Determination of Worst Case Operating Mode

1. EUT has been pre-tested under following test modes, and test **mode B** was the worst case for final test.

Mode	Test Condition
A	EUT installed in IPC+ LAN Mode (10Gbps)
B	EUT installed in IPC+ PoE Mode (1Gbps) <sup>Note</sup>

**Note: As client's request, using the maximum data rate of PoE Load (Supplied by client) is 1Gbps during the test.**

2. Test modes are presented in the report as below.

Mode	Test Condition	Input Power
Conducted emission test		
1	EUT installed in IPC+ PoE Mode (1Gbps)	36Vdc (System)
Radiated emission test		
1	EUT installed in IPC+ PoE Mode (1Gbps)	36Vdc (System)
Immunity tests		
1	EUT installed in IPC+ PoE Mode (1Gbps)	36Vdc (System)

### 3.4 Test Program Used and Operation Descriptions

#### Emission tests:

- a. Installed the EUT into IPC.
- b. Turned on the power of all equipment.
- c. IPC ran a test program to enable all functions.
- d. IPC read and wrote messages from/to storage.
- e. IPC sent and received messages to/from Notebook PCs (kept in a remote area) via EUT & PoE+ Spllter with UTP LAN cables. (10m each).
- f. IPC sent "H" patterns to ext. LCD Monitor. Then it displayed "H" patterns on its screen.
- g. IPC sent messages to printer and printer printed them out.
- h. IPC sent messages to modem.
- i. Steps d-h were repeated.

#### Immunity tests:

- a. Installed the EUT into IPC.
- b. Turned on the power of all equipment.
- c. IPC ran a test program to enable all functions.
- d. IPC read and wrote messages from/to storage.
- e. IPC sent and received messages to/from Notebook PCs (kept in a remote area) via EUT & PoE+ Spllter with UTP/STP LAN cables. (10m each).
- f. IPC sent color bars patterns to ext. LCD Monitor. Then it displayed color bar patterns on its screen.
- g. Steps d-f were repeated.

### 3.5 Primary Clock Frequencies of Internal Source

The highest frequency generated or used within the EUT or on which the EUT operates or tunes is 10GHz, provided by Vecow Co.,Ltd., for detailed internal source, please refer to the manufacturer's specifications.

## 4 Configuration and Connections with EUT

### 4.1 Connection Diagram of EUT and Peripheral Devices

Emission tests:

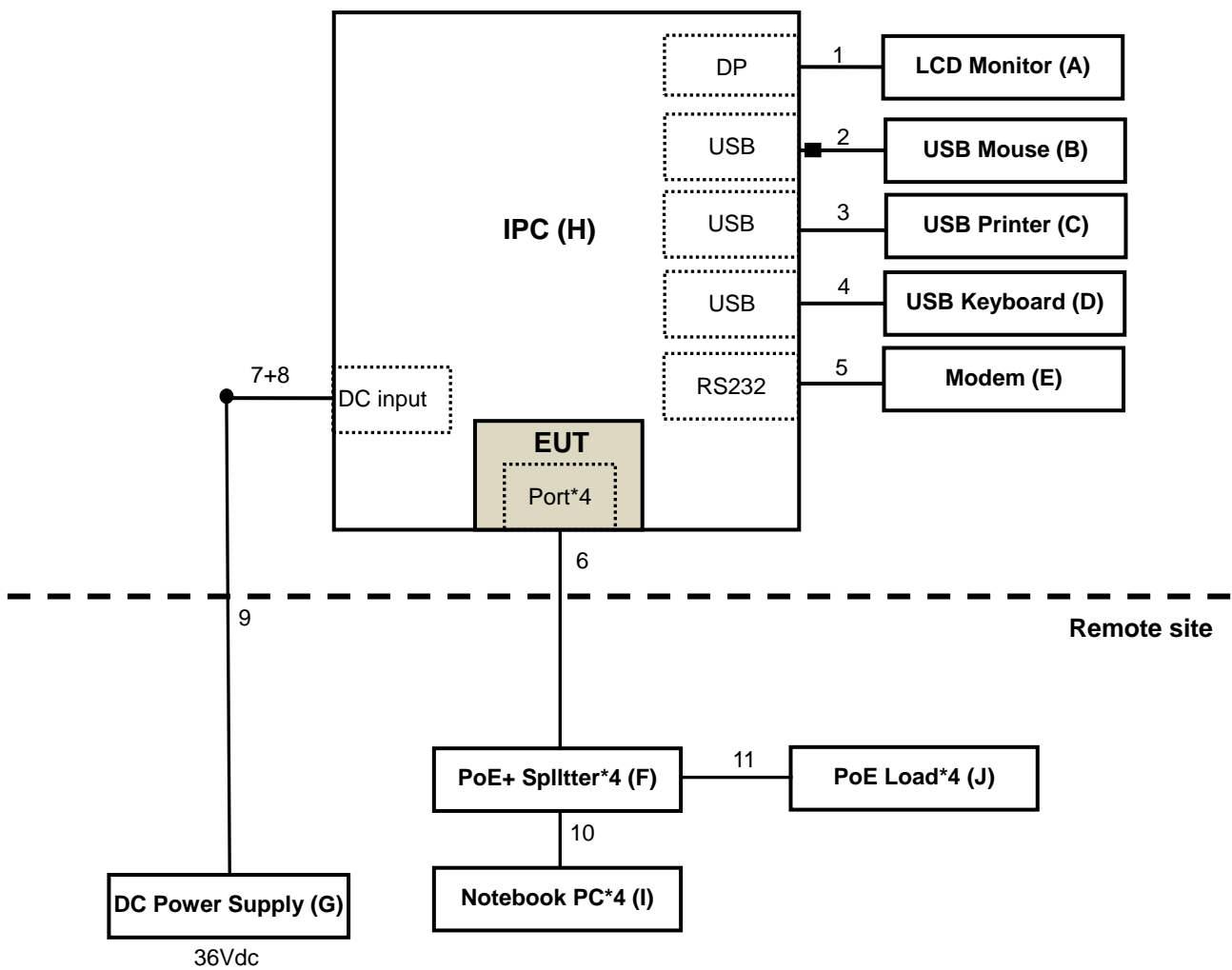

Immunity tests (ESD excluded):

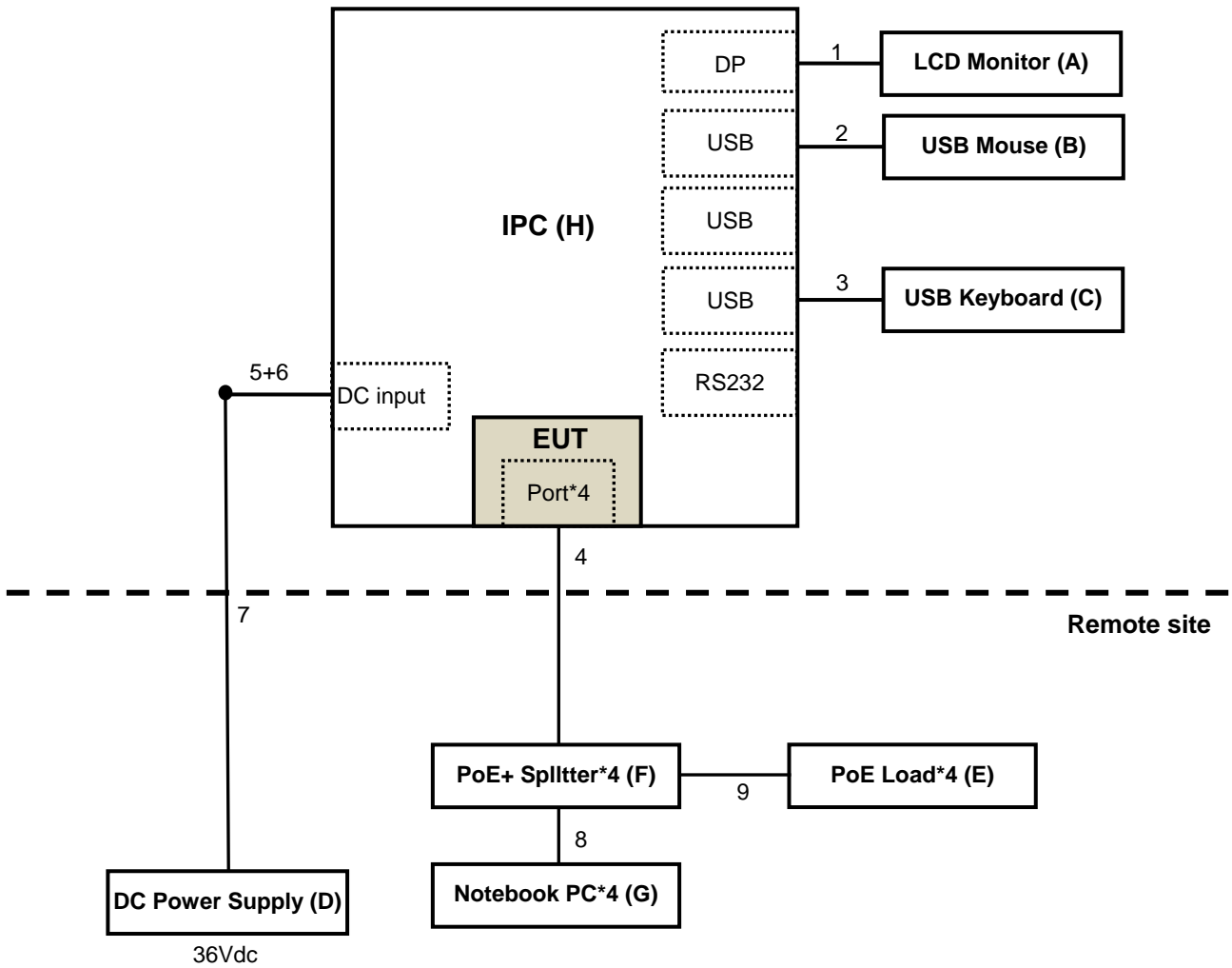

ESD test:

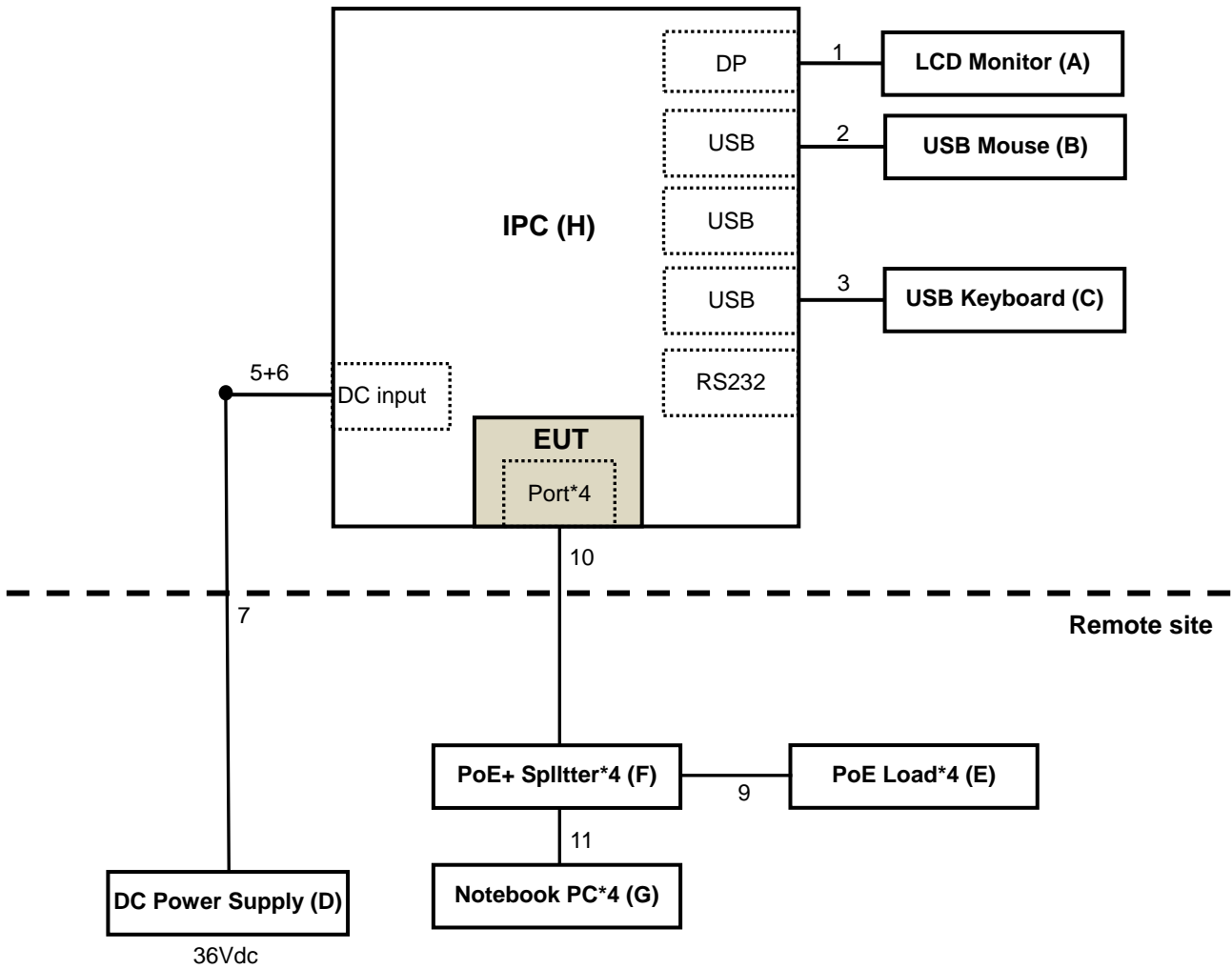

## 4.2 Configuration of Peripheral Devices and Cable Connections

### Emission tests:

ID	Product	Brand	Model No.	Serial No.	FCC ID	Remarks
A.	LCD Monitor	ASUS	MG28U	H1LMTF041254	N/A	Provided by Lab
B.	USB Mouse	Microsoft	1113	9170528317887	FCC DoC Approved	Provided by Lab
C.	USB PRINTER	HP	HP Officejet Pro 251dw	N/A	N/A	Provided by Lab
D.	USB Keyboard	Dell	KB216t	CN-0W33XP-LO300-7C L-1919	N/A	Provided by Lab
E.	MODEM	ACEEX	1414	980020508	IFAXDM1414	Provided by Lab
F.	10/100/1000M Gigabit PoE+ Spllter *4	GERIO	POE-PD04S	N/A	N/A	Supplied by client
G.	DC Power supply	CHROMA	62150H-600S	62150EC00479	N/A	Provided by Lab
H.	IPC	Vecow	RCS-9000	N/A	N/A	Supplied by client
I.	Notebook PC	LENOVO	T480	PF1EZSAW	N/A	Provided by Lab
	Notebook PC	LENOVO	T480	PF1EK03U	N/A	Provided by Lab
	Notebook PC	SONY	SVS151A12P	275548477001024	N/A	Provided by Lab
	Notebook PC	ASUS	PU401L	ECNXBC012528528	N/A	Provided by Lab
J.	PoE Load *4	N/A	N/A	N/A	N/A	Supplied by client

### Note:

1. All power cords of the above support units are non-shielded (1.8m).
2. Items G, I-J acted as communication partners to transfer data.

ID	Cable Descriptions	Qty.	Length (m)	Shielding (Yes/No)	Cores (Qty.)	Remarks
1.	Display cable	1	1.8	Y	0	Provided by Lab
2.	USB cable	1	1.8	Y	1	Provided by Lab
3.	USB cable	1	1.5	Y	0	Provided by Lab
4.	USB cable	1	1.8	Y	0	Provided by Lab
5.	RS232 cable	1	1.5	Y	0	Provided by Lab
6.	LAN cable	4	10	N	0	Provided by Lab (RJ45 Cat.5e)
7.	DC cable	1	0.12	N	0	Supplied by client
8.	DC cable	1	1.8	N	0	Provided by Lab
9.	DC cable	1	10	N	0	Provided by Lab
10.	LAN cable	4	1.8	N	0	Provided by Lab (RJ45 Cat.5e)
11.	DC cable	4	0.3	N	0	Provided by Lab

Note: The core(s) is(are) originally attached to the cable(s).

**Immunity tests:**

ID	Product	Brand	Model No.	Serial No.	FCC ID	Remarks
A.	24" LCD MONITOR	DELL	P2418HZM	CN-079XVV-TV200-8 CP-053T	N/A	Provided by Lab
B.	USB Mouse	HP	M-UCC31-O	N/A	N/A	Provided by Lab
C.	USB Keyboard	HP	KU-1060	N/A	N/A	Provided by Lab
D.	DC Power supply	CHROMA	62150H-600S	62150EC00479	N/A	Provided by Lab
E.	PoE Load *2	N/A	N/A	N/A	N/A	Supplied by client
F.	10/100/1000M Gigabit PoE+ Splltter *2	GERIO	POE-PD04S	N/A	N/A	Supplied by client
G.	Notebook PC	LENOVO	TP00057A	R9-0JMLFS16/01	N/A	Provided by Lab
	Notebook PC	LENOVO	L440	R90FCKH8	N/A	Provided by Lab
	Notebook PC	SONY	SVS151A12P	275548477001024	N/A	Provided by Lab
	Notebook PC	ASUS	PU401L	ECNXBC012528528	N/A	Provided by Lab
H.	IPC	Vecow	RCS-9000	N/A	N/A	Supplied by client

**Note:**

1. All power cords of the above support units are non-shielded (1.8m).
2. Items D-G acted as communication partners to transfer data.

ID	Cable Descriptions	Qty.	Length (m)	Shielding (Yes/No)	Cores (Qty.)	Remarks
1.	Display cable	1	1.8	Y	0	Provided by Lab
2.	USB cable	1	1.8	Y	0	Provided by Lab
3.	USB cable	1	1.8	Y	0	Provided by Lab
4.	LAN cable	4	10	N	0	Provided by Lab (RJ45 Cat.5e)
5.	DC cable	1	0.12	N	0	Supplied by client
6.	DC cable	1	1.8	N	0	Provided by Lab
7.	DC cable	1	10	N	0	Provided by Lab
8.	LAN cable	4	3.0	N	0	Provided by Lab (RJ45 Cat.5e)
9.	DC cable	4	0.1	N	0	Supplied by client
10.	LAN cable	4	10	Y	0	Provided by Lab (RJ45 Cat.5e)
11.	LAN cable	4	10	Y	0	Provided by Lab (RJ45 Cat.5e)

Note: The core(s) is(are) originally attached to the cable(s).



## 5 Conducted Disturbance at Auxiliary a.c. or d.c. Power Ports

### 5.1 Limits

Frequency (MHz)	Quasi-peak, (dBuV)
0.15 - 0.5	99
0.5 - 30	93

Notes: 1. The lower limit shall apply at the transition frequencies.  
 2. The limit decreases linearly with the logarithm of the frequency in the range of 0.15 to 0.50 MHz.

### 5.2 Test Instruments

Description & Manufacturer	Model No.	Serial No.	Cal. Date	Cal. Due
ROHDE & SCHWARZ TEST RECEIVER	ESR3	102413	Feb. 17, 2020	Feb. 16, 2021
ROHDE & SCHWARZ Artificial Mains Network (for EUT)	ESH2-Z5	100104	Dec. 13, 2019	Dec. 12, 2020
LISN With Adapter (for EUT)	AD10	C09Ada-001	Dec. 13, 2019	Dec. 12, 2020
ROHDE & SCHWARZ Artificial Mains Network (for peripherals)	ESH3-Z5	847265/023	Oct. 31, 2019	Oct. 30, 2020
SCHWARZBECK Artificial Mains Network (For EUT)	NNLK8129	8129229	May 14, 2019	May 13, 2020
SCHWARZBECK Artificial Mains Network (for EUT)	NSLK 8128	8128-244	Nov. 11, 2019	Nov. 10, 2020
Software	Cond_V7.3.7.4	NA	NA	NA
RF cable (JYEBAO) With 10dB PAD	5D-FB	Cable-C09.01	Aug. 15, 2019	Aug. 14, 2020
SUHNER Terminator (For ROHDE & SCHWARZ LISN)	65BNC-5001	E1-010789	May 13, 2019	May 12, 2020

Note: 1. The calibration interval of the above test instruments is 12 months and the calibrations are traceable to NML/ROC and NIST/USA.  
 2. The test was performed in Shielded Room No. 9.  
 3. The VCCI Site Registration No. C-11312.  
 4. Tested Date: Mar. 19, 2020

### 5.3 Test Arrangement

- The EUT was placed 0.4 meters from the conducting wall of the shielded room with EUT being connected to the power mains through a line impedance stabilization network (LISN). Other support units were connected to the power mains through another LISN. The two LISNs provide 50 Ohm/ 50uH of coupling impedance for the measuring instrument.
- Both lines of the power mains connected to the EUT were checked for maximum conducted interference.
- The test results of conducted emissions at mains ports are recorded of six worst margins for quasi-peak (mandatory) [and average (if necessary)] values against the limits at frequencies of interest unless the margin is 20 dB or greater.

Note: The resolution bandwidth and video bandwidth of test receiver is 9kHz for quasi-peak detection (QP) at frequency 0.15MHz-30MHz.

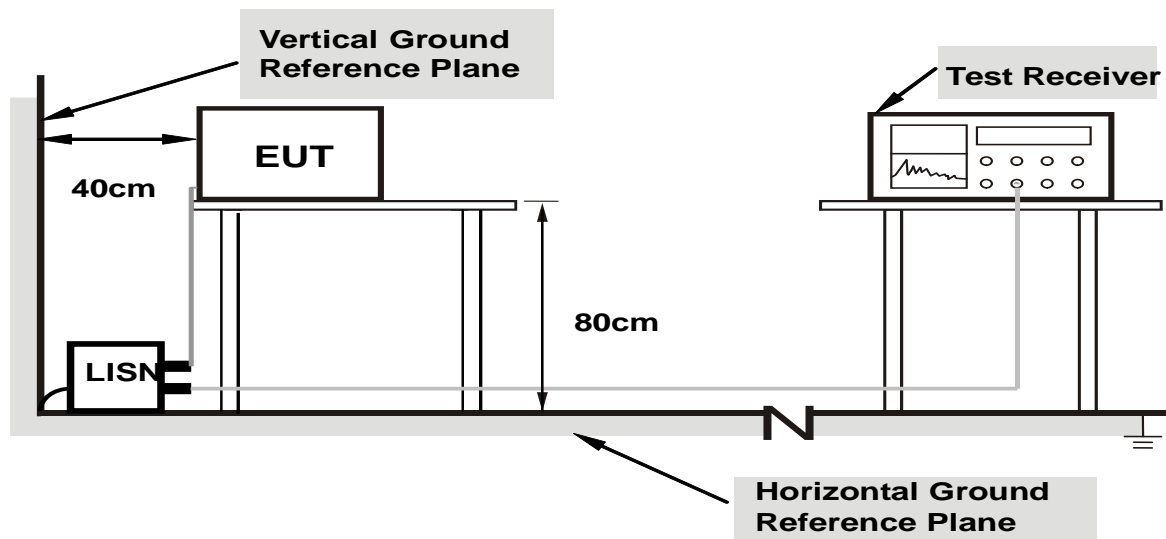

**Note: Support units were connected to second LISN.**

For the actual test configuration, please refer to the related item – Photographs of the Test Configuration.

### 5.4 Test Results

<b>Frequency Range</b>	150kHz ~ 30MHz	<b>Detector Function &amp; Bandwidth</b>	Quasi-Peak (QP), 9kHz
<b>Input Power (System)</b>	36Vdc	<b>Environmental Conditions</b>	21°C, 70%RH
<b>Tested by</b>	Chenghan Wu		
<b>Test Mode</b>	Mode 1		

Phase Of Power : Positive (+)						
No	Frequency (MHz)	Correction Factor (dB)	Reading Value (dBuV)	Emission Level (dBuV)	Limit (dBuV)	Margin (dB)
			Q.P.	Q.P.	Q.P.	Q.P.
1	0.25125	10.40	58.40	68.80	99.00	-30.20
2	0.32017	10.40	54.23	64.63	99.00	-34.37
3	0.49799	10.40	53.49	63.89	99.00	-35.11
4	0.64076	10.39	51.92	62.31	93.00	-30.69
5	0.74988	10.39	48.97	59.36	93.00	-33.64
6	0.99657	10.38	47.44	57.82	93.00	-35.18
7	1.28591	10.39	49.54	59.93	93.00	-33.07
8	1.49705	10.39	47.28	57.67	93.00	-35.33

**Remarks:**

1. Q.P. is abbreviation of quasi-peak.
2. The emission levels of other frequencies were very low against the limit.
3. Margin value = Emission level – Limit value
4. Correction factor = Insertion loss + Cable loss
5. Emission Level = Correction Factor + Reading Value

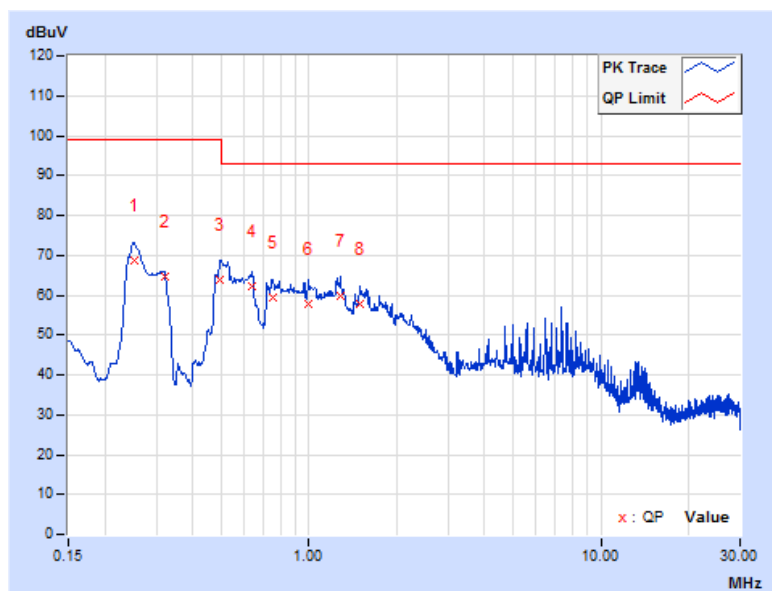

<b>Frequency Range</b>	150kHz ~ 30MHz	<b>Detector Function &amp; Bandwidth</b>	Quasi-Peak (QP), 9kHz
<b>Input Power (System)</b>	36Vdc	<b>Environmental Conditions</b>	21°C, 70%RH
<b>Tested by</b>	Chenghan Wu		
<b>Test Mode</b>	Mode 1		

Phase Of Power : Negative (-)						
No	Frequency (MHz)	Correction Factor (dB)	Reading Value (dBuV)	Emission Level (dBuV)	Limit (dBuV)	Margin (dB)
			Q.P.	Q.P.	Q.P.	Q.P.
1	0.25166	10.40	45.22	55.62	99.00	-43.38
2	0.49799	10.41	46.15	56.56	99.00	-42.44
3	0.62512	10.40	44.91	55.31	93.00	-37.69
4	0.74988	10.39	42.87	53.26	93.00	-39.74
5	1.15297	10.39	41.41	51.80	93.00	-41.20
6	7.33382	10.62	43.94	54.56	93.00	-38.44

**Remarks:**

1. Q.P. is abbreviation of quasi-peak.
2. The emission levels of other frequencies were very low against the limit.
3. Margin value = Emission level – Limit value
4. Correction factor = Insertion loss + Cable loss
5. Emission Level = Correction Factor + Reading Value

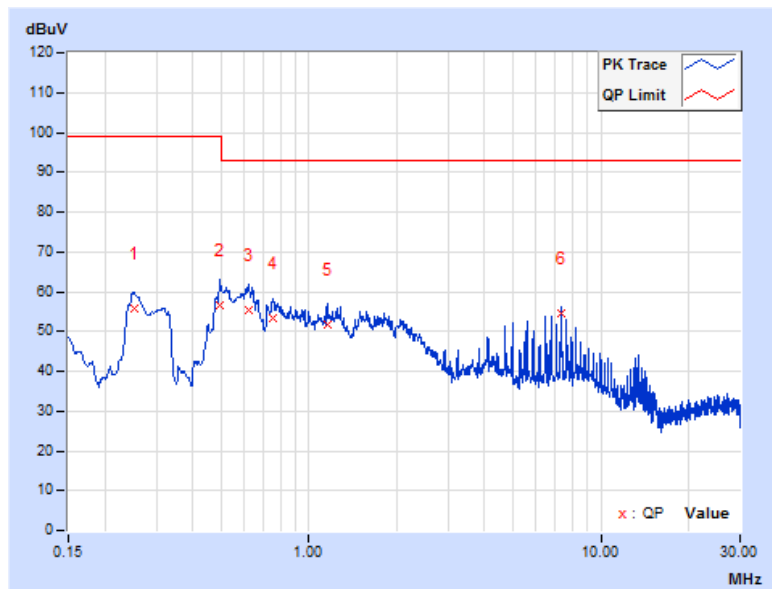

## 6 Radiated Disturbance up to 1 GHz

### 6.1 Limits

Frequency (MHz)	dBuV/m (at 10m) / quasi-peak
30 - 230	40
230 - 1000	47

- Notes:
1. The lower limit shall apply at the transition frequencies.
  2. Emission level (dBuV/m) = 20 log Emission level (uV/m).
  3. All emanations from a class A/B digital device or system, including any network of conductors and apparatus connected thereto, shall not exceed the level of field strengths specified above.

### 6.2 Test Instruments

Description & Manufacturer	Model No.	Serial No.	Cal. Date	Cal. Due
ROHDE & SCHWARZ TEST RECEIVER	ESCS 30	100027	May 13, 2019	May 12, 2020
Schwarzbeck Bilog Antenna	VULB9168	9168-303	Nov. 11, 2019	Nov. 10, 2020
Agilent Preamplifier	8447D	2944A08119	Feb. 19, 2020	Feb. 18, 2021
ADT. Turn Table	TT100	0205	NA	NA
ADT. Tower	AT100	0205	NA	NA
Software	Radiated_V7.6.15.9.5	NA	NA	NA
ADT RF Switches BOX	EMH-011	1001	Oct. 24, 2019	Oct. 23, 2020
Pacific RF cable With 5dB PAD	8D	CABLE-ST2-01	Oct. 24, 2019	Oct. 23, 2020

- Note:
1. The calibration interval of the above test instruments is 12 months and the calibrations are traceable to NML/ROC and NIST/USA.
  2. The test was performed in Open Site No. 2.
  3. The VCCI Site Registration No. R-10237.
  4. Tested Date: Mar. 20, 2020

### 6.3 Test Arrangement

- The EUT was placed on the top of a rotating table 0.8 meters above the ground at an accredited test facility. The table was rotated 360 degrees to determine the position of the highest radiation.
- The EUT was set 10 meters away from the interference-receiving antenna, which was mounted on the top of a variable-height antenna tower.
- The antenna is a broadband antenna, and its height is varied from one meter to four meters above the ground to determine the maximum value of the field strength. Both horizontal and vertical polarizations of the antenna are set to make the measurement.
- For each suspected emission, the EUT was arranged to its worst case and then the antenna was tuned to heights from 1 meter to 4 meters and the rotatable table was turned from 0 degrees to 360 degrees to find the maximum reading.
- The test-receiver system was set to quasi-peak detect function and specified bandwidth with maximum hold mode when the test frequency is up to 1 GHz.

Note: The resolution bandwidth and video bandwidth of test receiver/spectrum analyzer is 120kHz for quasi-peak detection (QP) at frequency up to 1GHz.

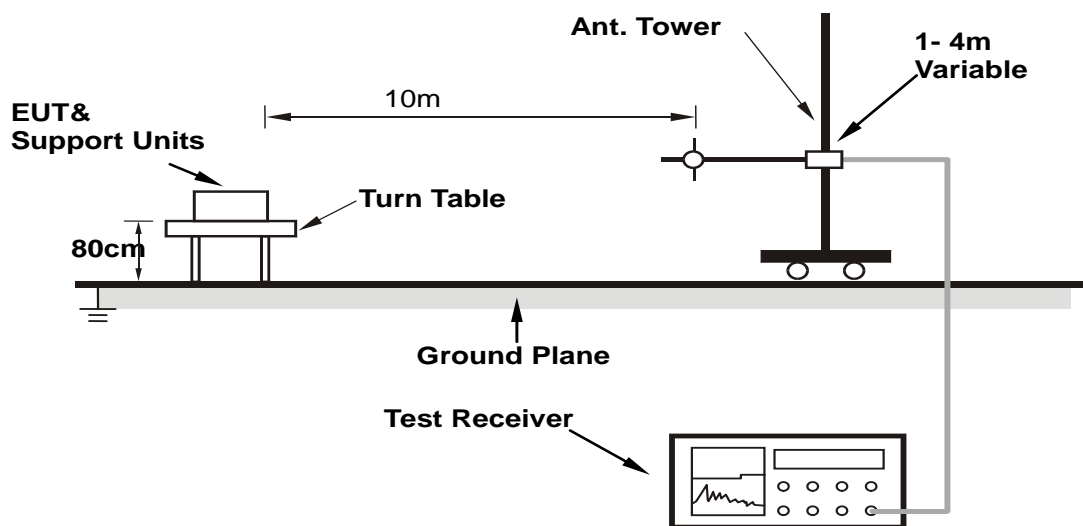

For the actual test configuration, please refer to the related item – Photographs of the Test Configuration.

## 6.4 Test Results

<b>Frequency Range</b>	30MHz ~ 1GHz	<b>Detector Function &amp; Bandwidth</b>	Quasi-Peak (QP), 120kHz
<b>Input Power (System)</b>	36Vdc	<b>Environmental Conditions</b>	22°C, 73%RH
<b>Tested by</b>	Paul Chen		
<b>Test Mode</b>	Mode 1		

### Antenna Polarity & Test Distance : Horizontal at 10 m

No	Frequency (MHz)	Emission Level (dBuV/m)	Limit (dBuV/m)	Margin (dB)	Antenna Height (m)	Table Angle (Degree)	Raw Value (dBuV)	Correction Factor (dB/m)
1	66.39	23.19 QP	40.00	-16.81	4.00 H	318	34.46	-11.27
2	125.00	26.64 QP	40.00	-13.36	4.00 H	130	37.69	-11.05
3	151.84	37.96 QP	40.00	-2.04	4.00 H	344	47.16	-9.20
4	217.17	26.48 QP	40.00	-13.52	4.00 H	58	38.24	-11.76
5	250.02	32.65 QP	47.00	-14.35	3.81 H	133	42.28	-9.63
6	500.00	31.14 QP	47.00	-15.86	2.07 H	39	34.53	-3.39
7	625.01	32.73 QP	47.00	-14.27	1.48 H	294	33.27	-0.54
8	875.02	32.96 QP	47.00	-14.04	1.00 H	273	28.19	4.77

#### Remarks:

1. Emission Level(dBuV/m) = Raw Value(dBuV) + Correction Factor(dB/m)
2. Correction Factor(dB/m) = Antenna Factor (dB/m) + Cable Factor (dB) – Pre-Amplifier Factor (dB)
3. The other emission levels were very low against the limit.
4. Margin value = Emission level – Limit value

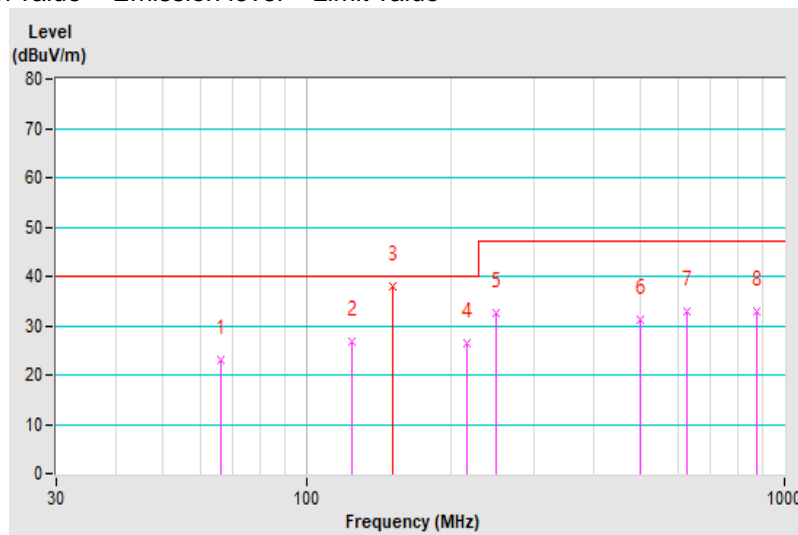

<b>Frequency Range</b>	30MHz ~ 1GHz	<b>Detector Function &amp; Bandwidth</b>	Quasi-Peak (QP), 120kHz
<b>Input Power (System)</b>	36Vdc	<b>Environmental Conditions</b>	22°C, 73%RH
<b>Tested by</b>	Paul Chen		
<b>Test Mode</b>	Mode 1		

Antenna Polarity & Test Distance : Vertical at 10 m								
No	Frequency (MHz)	Emission Level (dBuV/m)	Limit (dBuV/m)	Margin (dB)	Antenna Height (m)	Table Angle (Degree)	Raw Value (dBuV)	Correction Factor (dB/m)
1	72.11	31.84 QP	40.00	-8.16	1.49 V	111	44.50	-12.66
2	125.02	29.07 QP	40.00	-10.93	1.00 V	99	40.12	-11.05
<b>3</b>	<b>151.49</b>	<b>39.27 QP</b>	<b>40.00</b>	<b>-0.73</b>	<b>1.00 V</b>	<b>190</b>	<b>48.50</b>	<b>-9.23</b>
4	221.36	26.79 QP	40.00	-13.21	1.00 V	248	38.48	-11.69
5	250.02	32.09 QP	47.00	-14.91	1.00 V	145	41.72	-9.63
6	500.01	32.27 QP	47.00	-14.73	1.00 V	329	35.66	-3.39
7	625.00	30.66 QP	47.00	-16.34	3.14 V	299	31.20	-0.54
8	875.01	32.48 QP	47.00	-14.52	2.32 V	193	27.71	4.77

Remarks:

1. Emission Level(dBuV/m) = Raw Value(dBuV) + Correction Factor(dB/m)
2. Correction Factor(dB/m) = Antenna Factor (dB/m) + Cable Factor (dB) – Pre-Amplifier Factor (dB)
3. The other emission levels were very low against the limit.
4. Margin value = Emission level – Limit value

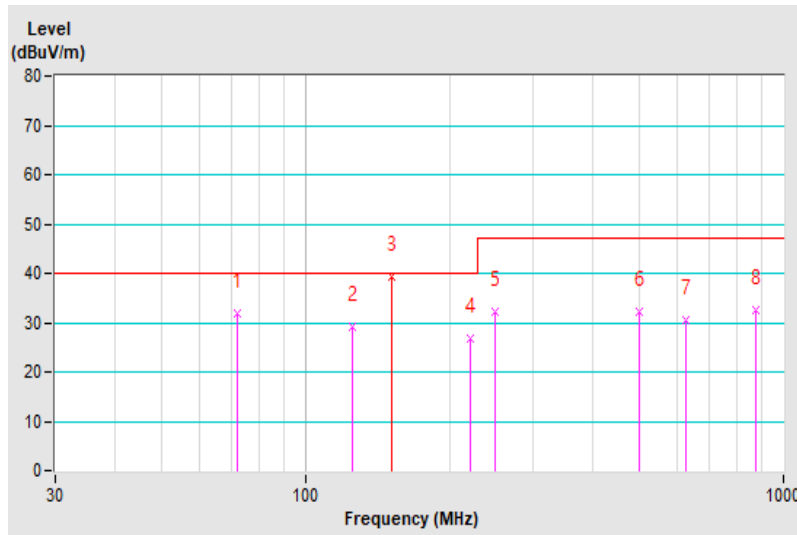



## 7 Radiated Disturbance above 1 GHz

### 7.1 Limits

Frequency (GHz)	dBuV/m (at 3m)	
	Average	Peak
1 to 3	56	76
3 to 6	60	80

- Notes: 1. The lower limit shall apply at the transition frequencies.  
 2. Emission level (dBuV/m) = 20 log Emission level (uV/m).  
 3. All emanations from a class A/B digital device or system, including any network of conductors and apparatus connected thereto, shall not exceed the level of field strengths specified above.

Frequency Range (For unintentional radiators)

Highest frequency generated or used in the EUT or on which the EUT operates or tunes (MHz)	Upper frequency of measurement range (MHz)
Below 108	1000
108-500	2000
500-1000	5000
Above 1000	Up to 5 times of the highest frequency or 6 GHz, whichever is less

### 7.2 Test Instruments

Description & Manufacturer	Model No.	Serial No.	Cal. Date	Cal. Due
Agilent Spectrum	E4446A	MY51100009	Jun. 6, 2019	Jun. 5, 2020
Agilent Test Receiver	N9038A	MY51210137	Jun. 6, 2019	Jun. 5, 2020
Agilent Preamplifier	8449B	3008A01292	Feb. 20, 2020	Feb. 19, 2021
MITEQ Preamplifier	AMF-6F-260400-33-8P	892164	Feb. 20, 2020	Feb. 19, 2021
EMCI Preamplifier	EMC184045B	980235	Feb. 20, 2020	Feb. 19, 2021
ETS Preamplifier	3117-PA	00215857	Nov. 24, 2019	Nov. 23, 2020
Schwarzbeck Horn Antenna	BBHA-9170	212	Nov. 24, 2019	Nov. 23, 2020
EMCO Horn Antenna	3115	6714	Nov. 24, 2019	Nov. 23, 2020
Max Full. Turn Table	MF7802	MF780208216	NA	NA
Software	Radiated_V8.7.08	NA	NA	NA
KIK + WOKEN RF cable With 3/4dB PAD	K1K50-UP0279-K1K50 -3000+WC01	Cable-CH10(3m) -04 +Cable-CH10-03	Jul. 10, 2019	Jul. 9, 2020
MICRO-TRONICS Notch filter	BRC50703-01	010	May 30, 2019	May 29, 2020
MICRO-TRONICS Band Pass Filter	BRM17690	005	May 30, 2019	May 29, 2020

- Note: 1. The calibration interval of the above test instruments is 12 months and the calibrations are traceable to NML/ROC and NIST/USA.  
 2. The 3dB beamwidth of the horn antenna is minimum 41degree (or w = 2.24m at 3m distance) for 1~6 GHz.  
 3. The test was performed in Chamber No. 10.  
 4. The VCCI Site Registration No. G-10427  
 5. Tested Date: Mar. 20 to 21, 2020

### 7.3 Test Arrangement

- The EUT was placed on the top of a rotating table 0.8 meters above the ground at an accredited chamber room. The table was rotated 360 degrees to determine the position of the highest radiation.
- The EUT was set 3 meters away from the interference-receiving antenna, which was mounted on the top of a variable-height antenna tower.
- The height of antenna can be varied from one meter to four meters, the height of adjustment depends on the EUT height and the antenna 3dB beamwidth both, to detect the maximum value of the field strength. Both horizontal and vertical polarizations of the antenna are set to make the measurement.
- For each suspected emission, the EUT was arranged to its worst case and then the antenna was tuned to heights and the rotatable table was turned from 0 degrees to 360 degrees to find the maximum reading.
- The spectrum analyzer system was set to peak and average detect function and specified bandwidth with maximum hold mode when the test frequency is above 1 GHz.

Note: The resolution bandwidth of test receiver/spectrum analyzer is 1MHz and video bandwidth is 3MHz for Peak detection (PK) at frequency above 1GHz. The resolution bandwidth of test receiver/spectrum analyzer is 1 MHz for Average detection (AV) at frequency above 1GHz.

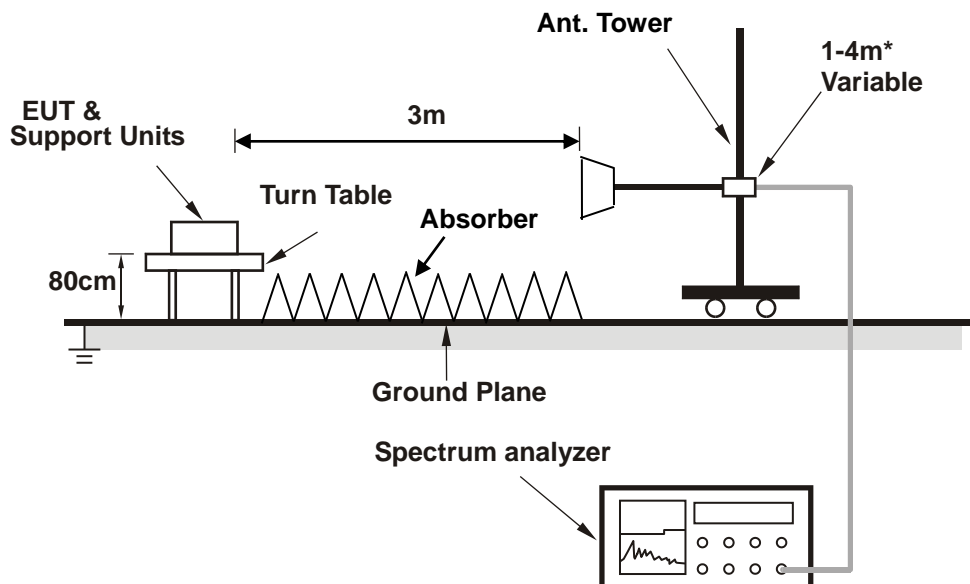

\* :depends on the EUT height and the antenna 3dB beamwidth both.

For the actual test configuration, please refer to the related item – Photographs of the Test Configuration.

### 7.4 Test Results

<b>Frequency Range</b>	1GHz ~ 6GHz	<b>Detector Function &amp; Bandwidth</b>	Peak (PK) / Average (AV), 1MHz
<b>Input Power (System)</b>	36Vdc	<b>Environmental Conditions</b>	20°C, 64%RH
<b>Tested by</b>	Vincent Lin		
<b>Test Mode</b>	Mode 1		

#### Antenna Polarity & Test Distance : Horizontal at 3 m

No	Frequency (MHz)	Emission Level (dBuV/m)	Limit (dBuV/m)	Margin (dB)	Antenna Height (m)	Table Angle (Degree)	Raw Value (dBuV)	Correction Factor (dB/m)
1	1066.78	50.81 PK	76.00	-25.19	2.50 H	216	53.79	-2.98
2	1066.78	31.24 AV	56.00	-24.76	2.50 H	216	34.22	-2.98
3	1500.20	50.53 PK	76.00	-25.47	1.00 H	129	53.34	-2.81
<b>4</b>	<b>1500.20</b>	<b>44.32 AV</b>	<b>56.00</b>	<b>-11.68</b>	<b>1.00 H</b>	<b>129</b>	<b>47.13</b>	<b>-2.81</b>
5	2126.33	53.40 PK	76.00	-22.60	2.30 H	125	54.53	-1.13
6	2126.33	33.10 AV	56.00	-22.90	2.30 H	125	34.23	-1.13

Remarks:

1. Emission Level(dBuV/m) = Raw Value(dBuV) + Correction Factor(dB/m)
2. Correction Factor(dB/m) = Antenna Factor (dB/m) + Cable Factor (dB) – Pre-Amplifier Factor (dB)
3. The other emission levels were very low against the limit.
4. Margin value = Emission level – Limit value

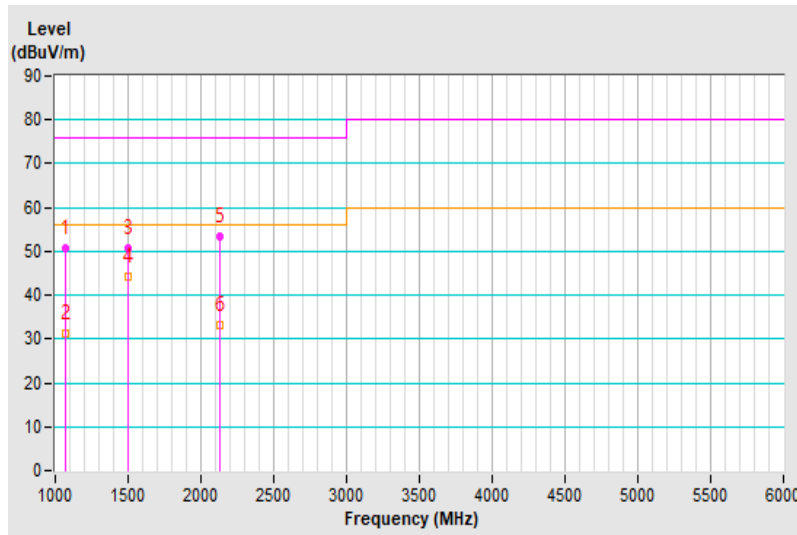

<b>Frequency Range</b>	1GHz ~ 6GHz	<b>Detector Function &amp; Bandwidth</b>	Peak (PK) / Average (AV), 1MHz
<b>Input Power (System)</b>	36Vdc	<b>Environmental Conditions</b>	20°C, 64%RH
<b>Tested by</b>	Vincent Lin		
<b>Test Mode</b>	Mode 1		

Antenna Polarity & Test Distance : Vertical at 3 m								
No	Frequency (MHz)	Emission Level (dBuV/m)	Limit (dBuV/m)	Margin (dB)	Antenna Height (m)	Table Angle (Degree)	Raw Value (dBuV)	Correction Factor (dB/m)
1	1241.12	52.98 PK	76.00	-23.02	2.26 V	188	56.71	-3.73
2	1241.12	29.21 AV	56.00	-26.79	2.26 V	188	32.94	-3.73
3	1499.99	49.23 PK	76.00	-26.77	1.66 V	352	52.04	-2.81
4	1499.99	42.94 AV	56.00	-13.06	1.66 V	352	45.75	-2.81
5	1932.40	54.54 PK	76.00	-21.46	2.43 V	151	56.15	-1.61
6	1932.40	32.47 AV	56.00	-23.53	2.43 V	151	34.08	-1.61

Remarks:

1. Emission Level(dBuV/m) = Raw Value(dBuV) + Correction Factor(dB/m)
2. Correction Factor(dB/m) = Antenna Factor (dB/m) + Cable Factor (dB) – Pre-Amplifier Factor (dB)
3. The other emission levels were very low against the limit.
4. Margin value = Emission level – Limit value

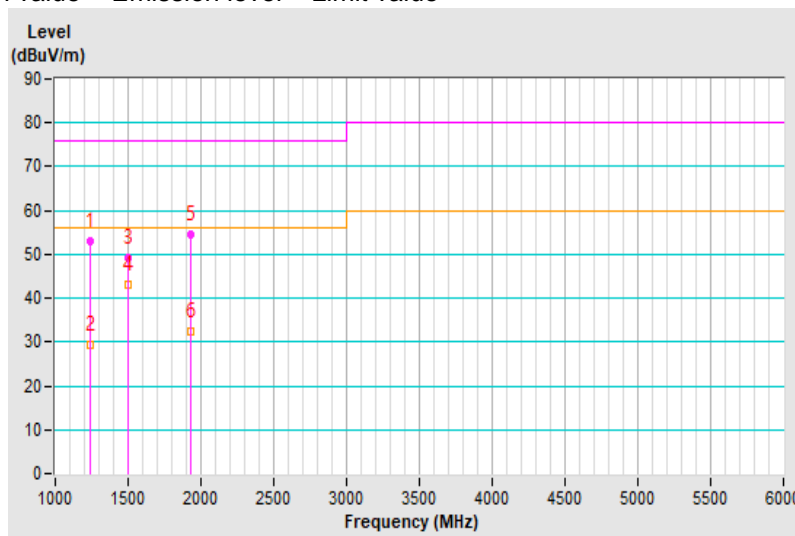

## 8 Electrostatic Discharge Immunity Test (ESD)

### 8.1 Test Specification

<b>Basic Standard:</b>	EN 61000-4-2
<b>Discharge Impedance:</b>	330 ohm / 150 pF
<b>Discharge Voltage:</b>	Air Discharge: $\pm 2$ , $\pm 4$ , $\pm 8$ kV (Direct) Contact Discharge: $\pm 2$ , $\pm 4$ kV, $\pm 6$ kV (Direct/Indirect)
<b>Number of Discharge:</b>	Minimum 20 times at each test point
<b>Discharge Mode:</b>	Single Discharge
<b>Discharge Period:</b>	1-second minimum

### 8.2 Test Instruments

Description & Manufacturer	Model No.	Serial No.	Cal. Date	Cal. Due
KeyTek, ESD Simulator	MZ-15/EC	0504259	Nov. 8, 2019	Nov. 7, 2020

- Note:
1. The calibration interval of the above test instruments is 12 months and the calibrations are traceable to NML/ROC and NIST/USA.
  2. The test was performed in ESD Room No. 2.
  3. Tested Date: Mar. 30, 2020

### 8.3 Test Arrangement

- a. Electrostatic discharges were applied only to those points and surfaces of the EUT that are accessible to users during normal operation.
- b. The test was performed with at least ten single discharges on the pre-selected points in the most sensitive polarity.
- c. The time interval between two successive single discharges was at least 1 second.
- d. The ESD generator was held perpendicularly to the surface to which the discharge was applied and the return cable was at least 0.2 meters from the EUT.
- e. Contact discharges were applied to the non-insulating coating, with the pointed tip of the generator penetrating the coating and contacting the conducting substrate.
- f. Air discharges were applied with the round discharge tip of the discharge electrode approaching the EUT as fast as possible (without causing mechanical damage) to touch the EUT. After each discharge, the ESD generator was removed from the EUT and re-triggered for a new single discharge. The test was repeated until all discharges were complete.
- g. At least ten single discharges (in the most sensitive polarity) were applied to the **Horizontal Coupling Plane** at points on each side of the EUT. The ESD generator was positioned at a distance of 0.1 meters from the EUT with the discharge electrode touching the **HCP**.
- h. At least ten single discharges (in the most sensitive polarity) were applied to the center of one vertical edge of the **Vertical Coupling Plane** in sufficiently different positions that the four faces of the EUT were completely illuminated. The **VCP** (dimensions 0.5m x 0.5m) was placed vertically to and 0.1 meters from the EUT.

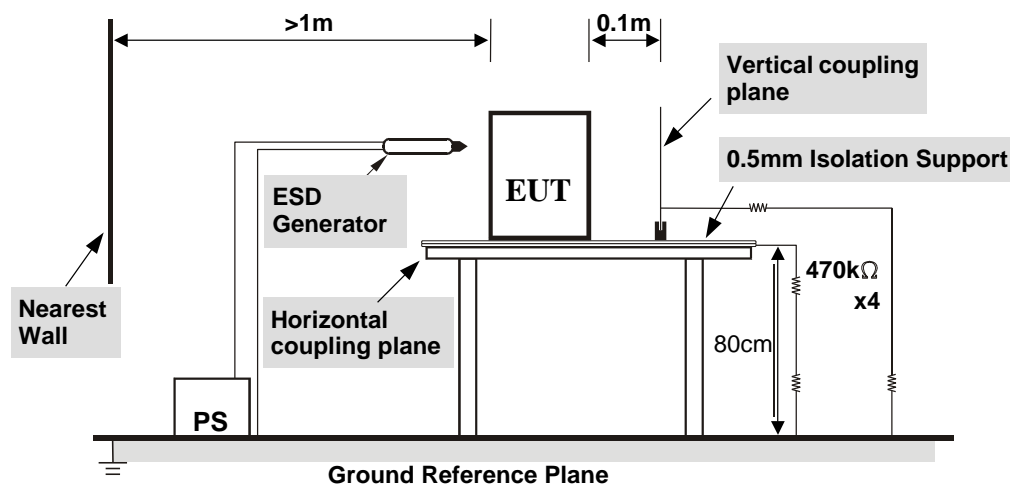

#### TABLE-TOP EQUIPMENT

The configuration consisted of a wooden table 0.8 meters high standing on the **Ground Reference Plane**. The **GRP** consisted of a sheet of aluminum at least 0.25mm thick, and 2.5 meters square connected to the protective grounding system. A **Horizontal Coupling Plane** (1.6m x 0.8m) was placed on the table and attached to the **GRP** by means of a cable with 940kΩ total impedance. The equipment under test, was installed in a representative system as described in section 7 of EN 61000-4-2, and its cables were placed on the **HCP** and isolated by an insulating support of 0.5mm thickness. A distance of 1-meter minimum was provided between the EUT and the walls of the laboratory and any other metallic structure.

For the actual test configuration, please refer to the related item – Photographs of the Test Configuration.

#### 8.4 Test Results

Input Power	36Vdc (System)	Tested by	Thomas Cheng
Environmental Conditions	22 °C, 47% RH 1010 mbar	Test mode	Mode 1

##### Test Results of Direct Application

Discharge Level (kV)	Polarity (+/-)	Test Point	Contact Discharge	Air Discharge	Performance Criterion
2, 4	+/-	1-2	Note 1	N/A	A
6	+/-	1-2	Note 2	N/A	B
2, 4, 8	+/-	3-4	N/A	Note 1	A

Description of test points of direct application: Please refer to following page for representative mark only.

##### Test Results of Indirect Application

Discharge Level (kV)	Polarity (+/-)	Test Point	Horizontal Coupling Plane	Vertical Coupling Plane	Performance Criterion
2, 4, 6	+/-	Four Sides	Note 1	Note 1	A

Description of test points of indirect application:

1. Front side                      2. Rear side                      3. Right side                      4. Left side

Note: 1. The EUT function was correct during the test.  
2. LAN was link down 3 seconds during the test, but could self-recover after the test.

## Description of Test Points

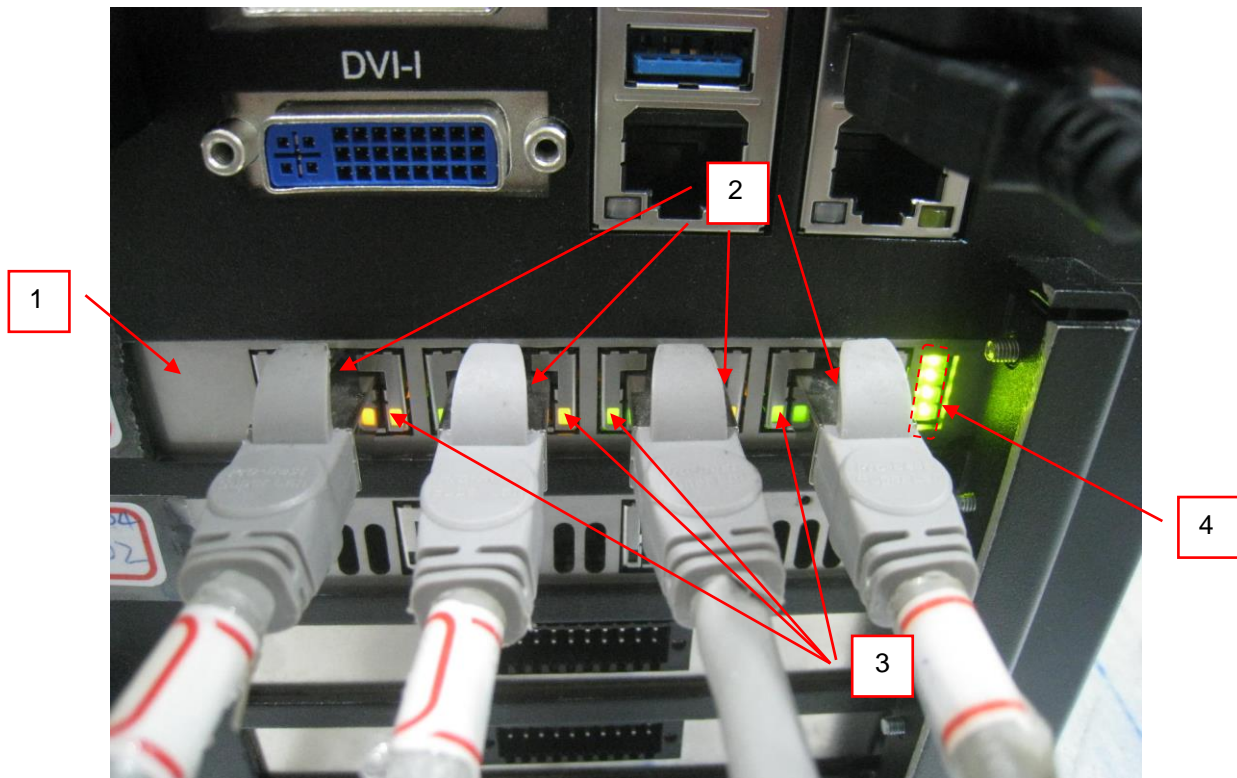



## 9 Radio-frequency Electromagnetic Field Immunity Test (RS)

### 9.1 Test Specification

Basic Standard:	EN 61000-4-3
Frequency Range, Field Strength:	80-800 MHz, 20V/m <sup>1</sup>
	800-1000 MHz, 20V/m
	1400-2000 MHz, 10V/m
	2000-2700 MHz, 5V/m
Modulation:	5100-6000 MHz, 3V/m
	1kHz Sine Wave, 80%, AM Modulation
Frequency Step:	1 % of preceding frequency value
Polarity of Antenna:	Horizontal and Vertical
Antenna Height:	1.5m
Dwell Time:	3 seconds

Note 1: This limit applies to equipment mounted in the passenger compartments, drivers cab or external to the rolling stock (roof, underframe). For equipment mounted in all other areas a severity level of 10 V/m may be used.

### 9.2 Test Instruments

Description & Manufacturer	Model No.	Serial No.	Cal. Date	Cal. Due
AgilentSignal Generator	E8257D	MY48050465	Jun. 7, 2019	Jun. 6, 2020
BONN RF Amplifier	BSA 0125-800	1912556	NA	NA
TESTQAmplifier	CBA 1G-275	T44344	NA	NA
AR RF Amplifier	35S4G8AM4	0326094	NA	NA
AR RF Amplifier	100S1G4M3	0329249	NA	NA
AR Controller	SC1000M3	305910	NA	NA
ETS Electric Field Sensor	HI-6105	00217912	Aug. 13, 2019	Aug. 12, 2020
BOONTON RF Voltage Meter	4232A	10180	May 29, 2019	May 28, 2020
BOONTON Power Sensor	51011-EMC	34152	May 29, 2019	May 28, 2020
BOONTON Power Sensor	51011-EMC	34153	May 29, 2019	May 28, 2020
ARLog-Periodic Antenna	AT6080	0329465	NA	NA
EMCO BiconiLog Antenna	3141	1001	NA	NA
ARHigh Gain Antenna	AT4010	0329800	NA	NA
SchwarzbeckLOG ANTENNA	Stlp 9149	9149-260	NA	NA
CHANCE MOST Full Anechoic Chamber (9x5x3m)	Chance Most	RS-002	Feb. 5, 2020	Feb. 4, 2021
Software	RS_V7.6	NA	NA	NA

- Note:
1. The calibration interval of the above test instruments is 12 months and the calibrations are traceable to NML/ROC and NIST/USA.
  2. The test was performed in RS Room No.2.
  3. The transmit antenna was located at a distance of 3 meters/ 1.5 meters from the EUT.
  4. Tested Date: Mar. 26, 2020

1.

### 9.3 Test Arrangement

The test procedure was in accordance with EN 61000-4-3.

- a. The testing was performed in a fully anechoic chamber.
- b. The frequency ranges and field strength levels are 80-800 MHz, 20V/m, 800-1000 MHz, 20V/m, 1400-2000 MHz, 10V/m, 2000-2700 MHz, 5V/m and 5100-6000 MHz, 3V/m with the signal 80% amplitude modulated with a 1kHz sine wave.
- c. The test was performed with the EUT exposed to both vertically and horizontally polarized fields on each of the four sides.

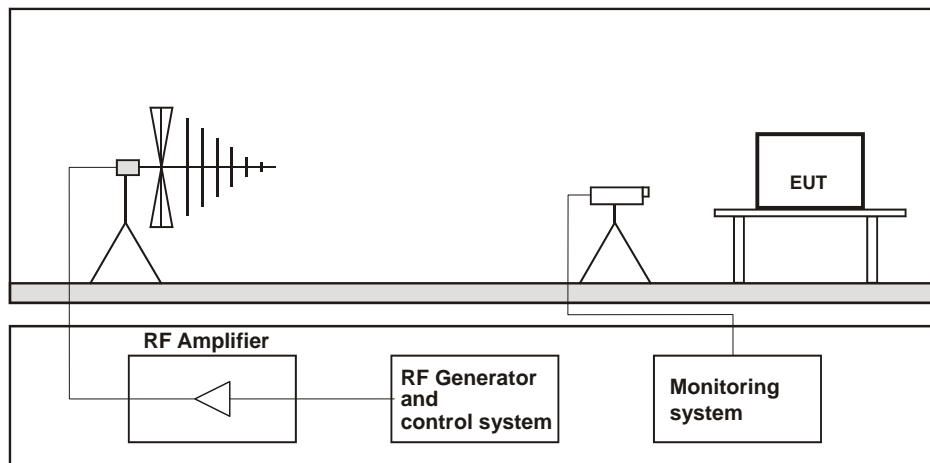

#### Table-top Equipment

The EUT installed in a representative system as described in section 7 of EN 61000-4-3 was placed on a non-conductive table 0.8 meters in height. The system under test was connected to the power and signal wire according to relevant installation instructions.

For the actual test configuration, please refer to the related item – Photographs of the Test Configuration.

#### 9.4 Test Results

Input Power	36Vdc (System)	Tested by	Thomas Cheng
Environmental Conditions	22 °C, 66% RH	Test mode	Mode 1

Frequency (MHz)	Polarity	Azimuth(°)	Applied Field Strength		Test Distance (m)	Observation	Performance Criterion
			(V/m)	Modulation			
80 - 800	V&H	0, 90, 180, 270	20	80% AM (1kHz)	1.5	Note	A
800 - 1000	V&H	0, 90, 180, 270	20	80% AM (1kHz)	1.5	Note	A
1400 - 2000	V&H	0, 90, 180, 270	10	80% AM (1kHz)	3	Note	A
2000 - 2700	V&H	0, 90, 180, 270	5	80% AM (1kHz)	3	Note	A
5100 - 6000	V&H	0, 90, 180, 270	3	80% AM (1kHz)	3	Note	A

Note: The EUT function was correct during the test.

## 10 Electrical Fast Transient/Burst Immunity Test (EFT)

### 10.1 Test Specification

Basic Standard:	EN 61000-4-4
Test Voltage:	Signal & communication, process measurement & control ports: $\pm 2$ kV, Capacitive clamp Battery referenced ports (except at the output of energy sources), Auxiliary a.c. power input ports (rated voltage $\leq 400$ Vrms): N/A
Impulse Repetition Frequency:	5kHz
Impulse Wave Shape:	5/50 ( $T_r/T_h$ ) ns
Burst Duration:	15 ms
Burst Period:	300 ms
Test Duration:	1 min.

### 10.2 Test Instruments

Description & Manufacturer	Model No.	Serial No.	Cal. Date	Cal. Due
TESEQ, EFT Simulator	NSG 3060	1572	May 22, 2019	May 21, 2020
TESEQ, CDN	CDN 3083-B100	303	May 22, 2019	May 21, 2020
Haefely, Capacitive Clamp	IP4A	155173	Apr. 23, 2019	Apr. 22, 2020

- Note:
1. The calibration interval of the above test instruments is 12 months and the calibrations are traceable to NML/ROC and NIST/USA.
  2. The test was performed in EMS Room No. 2.
  3. Tested Date: Mar. 26, 2020



## 11 Immunity to Conducted Disturbances Induced by RF Fields (CS)

### 11.1 Test Specification

Basic Standard:	EN 61000-4-6
Frequency Range:	0.15 MHz - 80 MHz
Voltage Level:	Battery referenced ports (except at the output of energy sources), Auxiliary a.c. power input ports (rated voltage $\leq$ 400 Vrms), Signal & communication, process measurement & control ports: 10 V
Modulation:	1kHz Sine Wave, 80%, AM Modulation
Frequency Step:	1 % of preceding frequency value
Dwell Time	3 seconds

### 11.2 Test Instruments

Description & Manufacturer	Model No.	Serial No.	Cal. Date	Cal. Due
ROHDE & SCHWARZ Signal Generator	SML03	101801	Jan. 17, 2020	Jan. 16, 2021
Digital Sweep Function Generator	8120	984801	NA	NA
AR Power Amplifier	75A250AM1	306331	NA	NA
FCC Coupling Decoupling Network	FCC-801-M2-16A	01047	Jun. 19, 2019	Jun. 18, 2020
FISCHER CUSTOM COMMUNICATIONS EM Injection Clamp	F-203I-23mm	455	NA	NA
FISCHER CUSTOM COMMUNICATIONS Current Injection Clamp	F-120-9A	361	Jul. 31, 2019	Jul. 30, 2020
B&K Ear Simulator	4185	2553594	NA	NA
EM TEST Coupling Decoupling Network	CDN M1/32A	306508	Jun. 19, 2019	Jun. 18, 2020
TESEQ Coupling Decoupling Network	CDN T800	34428	Jun. 19, 2019	Jun. 18, 2020
TESEQ Coupling Decoupling Network	CDN T800	29459	Jun. 19, 2019	Jun. 18, 2020
FCC Coupling Decoupling Network	FCC-801-T4	02031	Jun. 19, 2019	Jun. 18, 2020
EM TEST Coupling Decoupling Network	CDN T2	306509	Jun. 19, 2019	Jun. 18, 2020
R&S Power Sensor	NRV-Z5	837878/039	Nov. 8, 2019	Nov. 7, 2020
R&S Power Meter	NRVD	837794/040	Nov. 8, 2019	Nov. 7, 2020
TESEQ Coupling Decoupling Network	CDN M232	37702	Jun. 19, 2019	Jun. 18, 2020
TESEQ Coupling Decoupling Network	CDN M332	41258	Jun. 19, 2019	Jun. 18, 2020
TESEQ Coupling Decoupling Network	CDN M332	41256	Jun. 19, 2019	Jun. 18, 2020
TESEQ Coupling Decoupling Network	CDN T8-10	40376	Jun. 19, 2019	Jun. 18, 2020
TESEQ Coupling Decoupling Network	CDN S751S	35791	Mar. 5, 2020	Mar. 4, 2021
TESEQ Coupling Decoupling Network	CDN S200	53490	May 28, 2019	May 27, 2020
TESEQ Coupling Decoupling Network	CDN S400	52115	Jul. 23, 2019	Jul. 22, 2020
TESEQ Coupling Decoupling Network	ISN ST08	41212	Jun. 19, 2019	Jun. 18, 2020
FCC Coupling Decoupling Network	FCC-801-M5-50A	100018	Jan. 20, 2020	Jan. 19, 2021
Software	CS_V7.4.2	NA	NA	NA

- Note:
1. The calibration interval of the above test instruments is 12 months and the calibrations are traceable to NML/ROC and NIST/USA.
  2. The test was performed in CS Room No. 1.
  3. Tested Date: Mar. 24, 2020



#### 11.4 Test Results

Input Power	36Vdc (System)	Tested by	Thomas Cheng
Environmental Conditions	22 °C, 62% RH	Test mode	Mode 1

Frequency (MHz)	Level (V rms)	Tested Line	Injection Method	Return Path	Observation	Remark	Performance Criterion
0.15 – 80	10	LAN	CDN-T8-10	CDN-M3	Note	-	A

Note: The EUT function was correct during the test.



## 12 Pictures of Test Arrangements

### 12.1 Conducted Disturbance at Auxiliary a.c. or d.c. power ports



## 12.2 Radiated Disturbance up to 1 GHz





### 12.3 Radiated Disturbance above 1 GHz

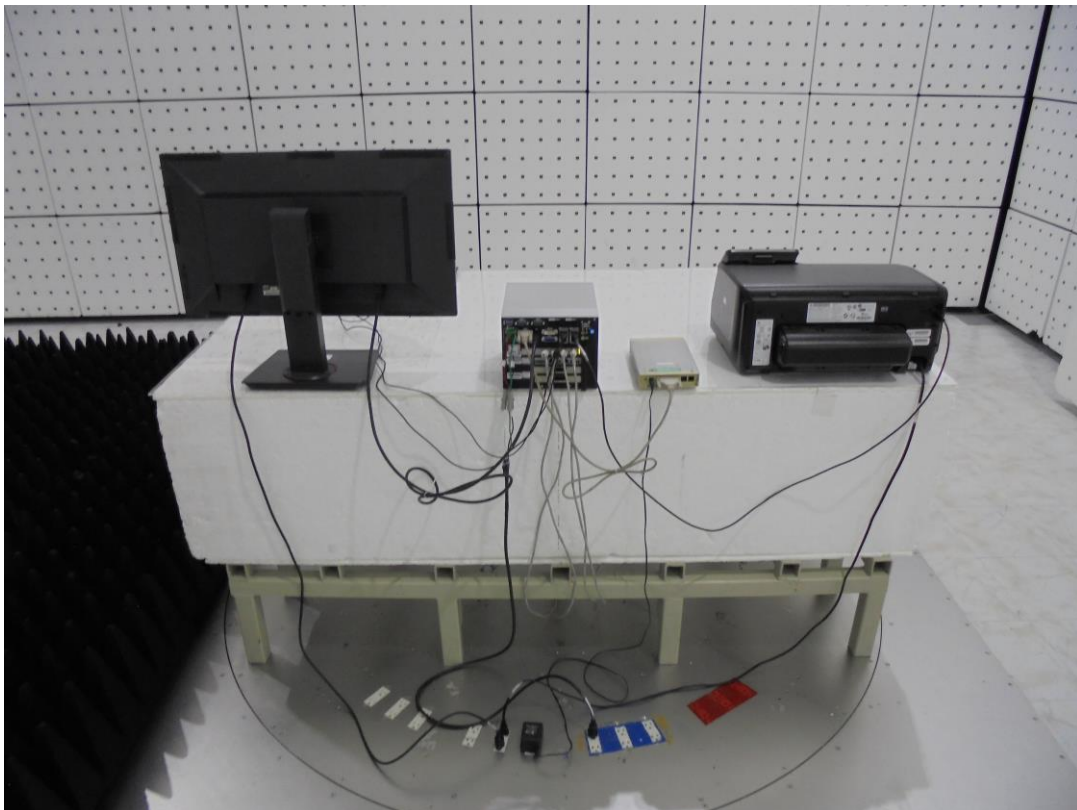

## 12.4 Electrostatic Discharge Immunity Test (ESD)



## 12.5 Radio-frequency Electromagnetic Field Immunity Test (RS)

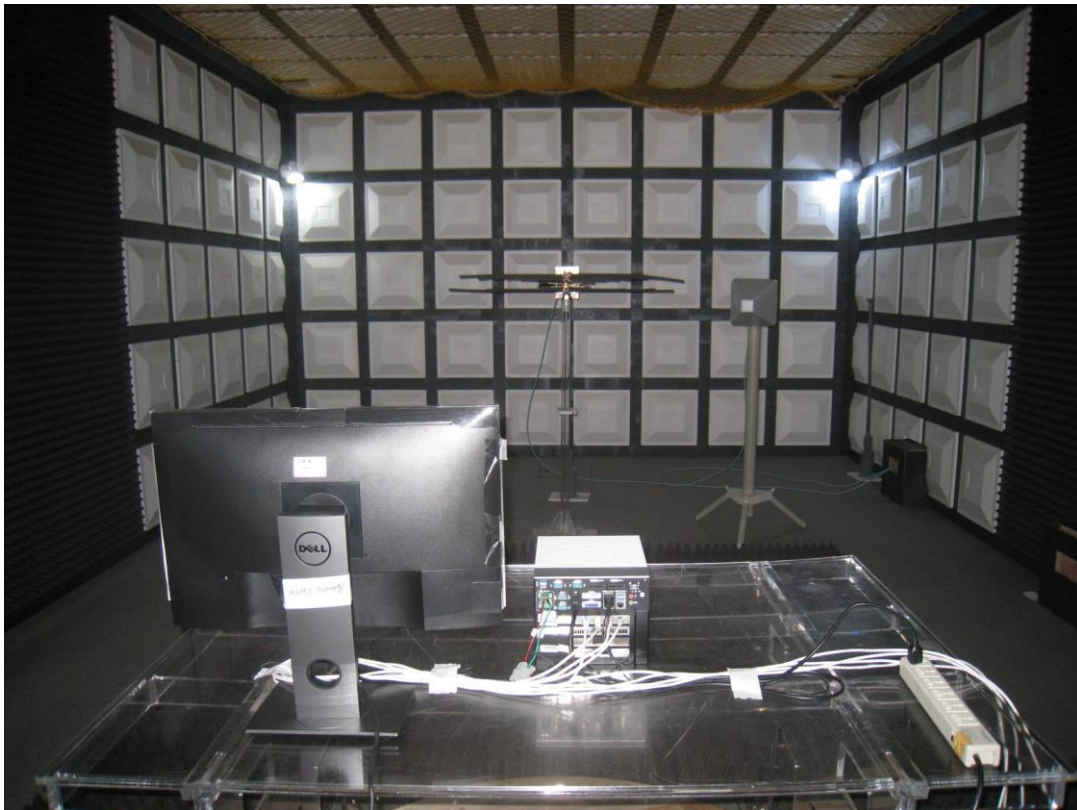
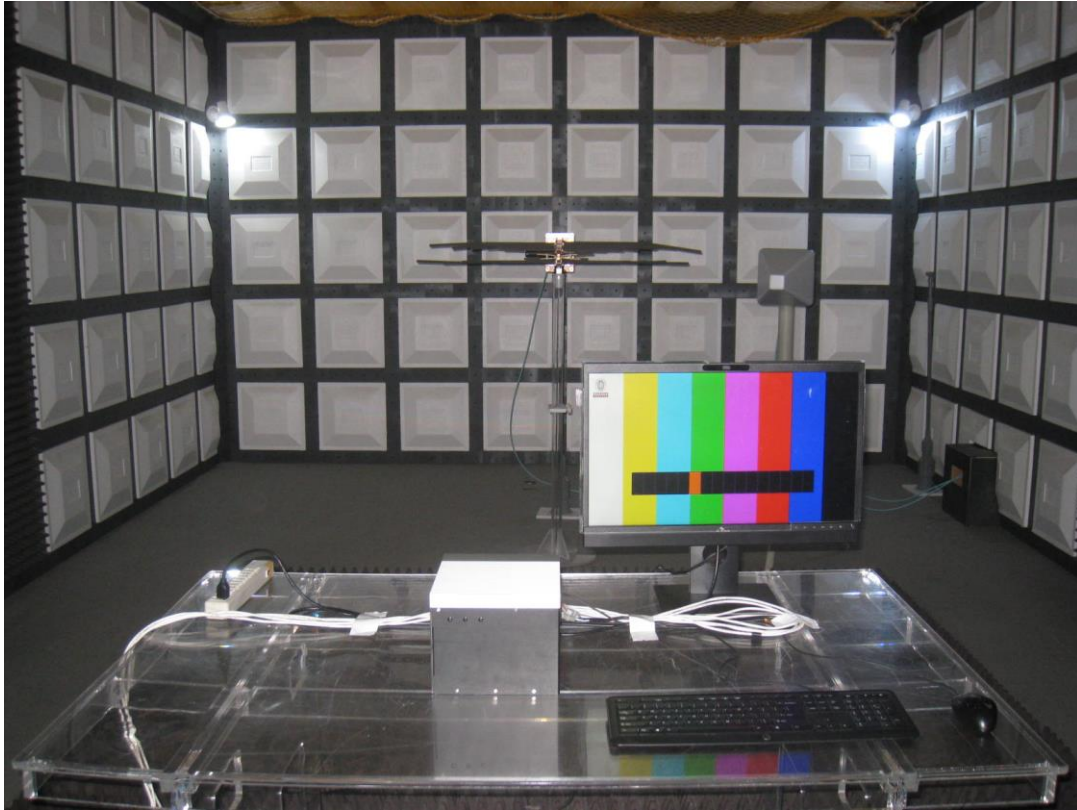



### 12.6 Fast Transients (EFT)

Signal ports

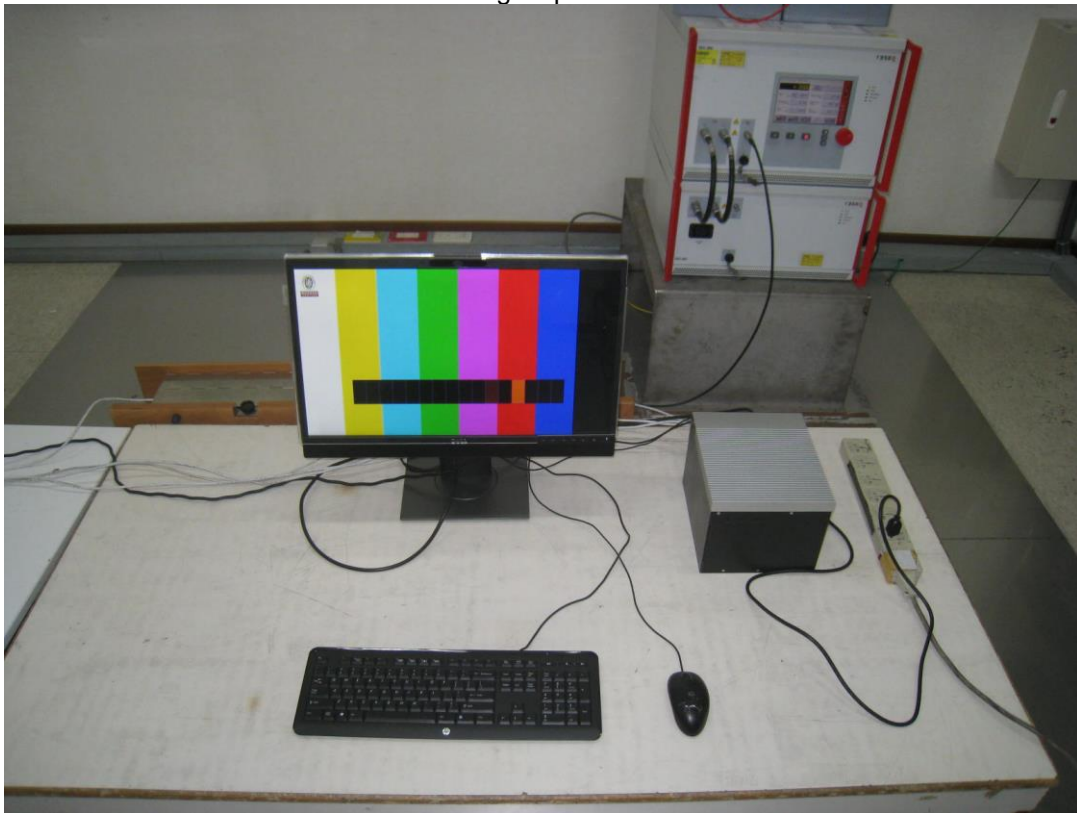

### 12.7 Radio-frequency common mode (CS)

Signal ports

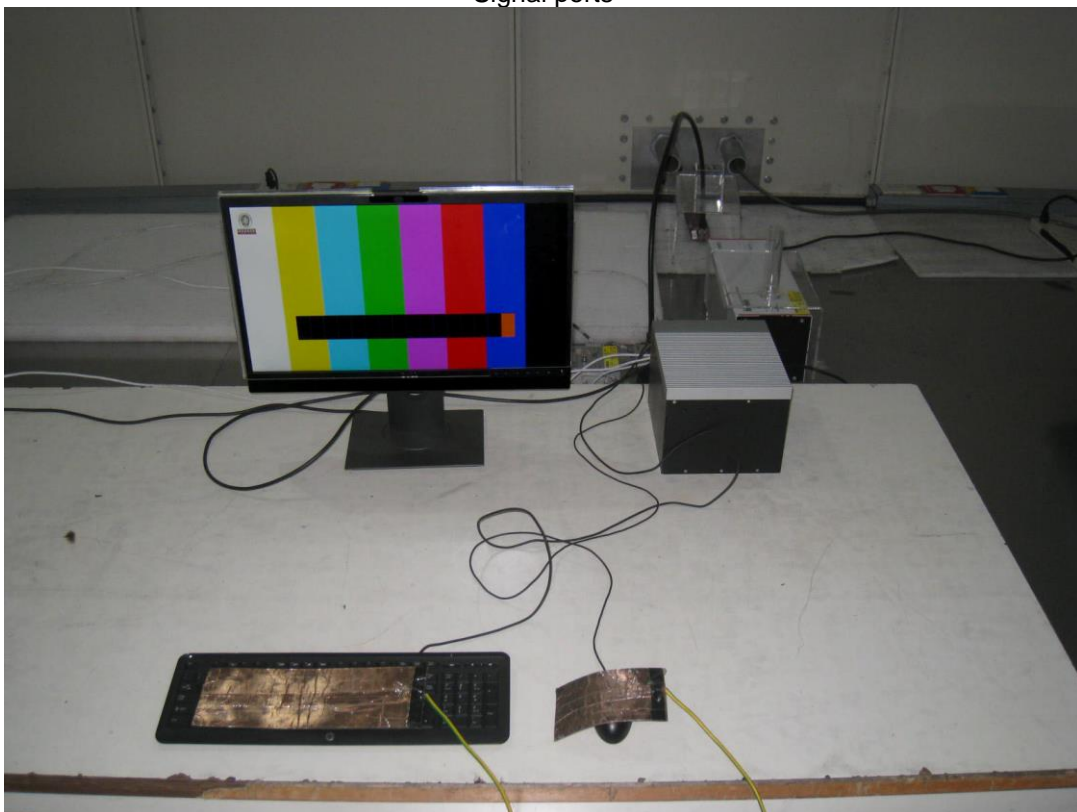

## Appendix – Information of the Testing Laboratories

We, Bureau Veritas Consumer Products Services (H.K.) Ltd., Taoyuan Branch, were founded in 1988 to provide our best service in EMC, Radio, Telecom and Safety consultation. Our laboratories are accredited and approved according to ISO/IEC 17025.

If you have any comments, please feel free to contact us at the following:

**Lin Kou EMC/RF Lab**

Tel: 886-2-26052180

Fax: 886-2-26051924

**Hsin Chu EMC/RF/Telecom Lab**

Tel: 886-3-6668565

Fax: 886-3-6668323

**Hwa Ya EMC/RF/Safety Lab**

Tel: 886-3-3183232

Fax: 886-3-3270892

**Email:** [service.adt@tw.bureauveritas.com](mailto:service.adt@tw.bureauveritas.com)

**Web Site:** [www.bureauveritas-adt.com](http://www.bureauveritas-adt.com)

The address and road map of all our labs can be found in our web site also.

--- END ---